18.5V, 4 Rail Power Management IC with Safety Monitoring for Camera Modules AEC-Q100 Qualified

DESCRIPTION

The LPC700 is a complete power management solution, which integrates three high efficiency step-down DC/DC converters, and high-PSRR LDO, and flexible logic interface.

The Buck1 step-down converter has an input voltage range up to 18.5V for the power over Coax(PoC). All step down converters operate in a forced fixed-frequency PWM mode. 2.2MHz or 3.3MHz selectable switching frequency during CCM mode greatly reduces external inductor and capacitor value. Full protection features include UVLO, OCP, OVP and thermal shutdown.

The LPC700 requires a minimal number of external components, and is available in space-saving 16-pin QFN (3mmx3mm).

Features

- AEC-Q100 Grade 1
- FMEA Compliant Pin Placement and Protection Mechanisms
- Three Step-Down Converters (HVBuck1, LVBuck2 and LVBuck3)
 - Peak Current Mode PWM Operation
 - Selectable Switching Frequency at 2.2MHz or 3.3MHz
 - Stepped Triangle Spread Spectrum with on/off Function
- HVBuck1 Input Voltage from 4V to 18.5V, Adjustable Output Voltage and Up to 2A Output Current
 - LVBuck2 Input Voltage from 2.7V to 5V, Fixed Output Voltage and 1.5A Output Current

- LVBuck3 Input Voltage from 2.7V to 5V, Fixed Output Voltage and 750mA Output Current
- Low Dropout Regulator (LDO)
 - Input Voltage from 2.7V to 5V and 300mA Output Current
 - 10 Adjustable Output Voltage Settings via RSET Pin
 - High PSRR : 60dB at 100kHz, 55dB at 2MHz
 - Pins Related to LVBuck2/LVBuck3 Allowable Floating if Channel Unused
- I2C Interface feedback the faults to MCU
- Output Function
 - Sequence Control for External resistor
 - Power Status Indication via PG
- 6 Flexible Power Sequence Settings via SEQ Pin
- Small Form Factor QFN-16L 3x3

APPLICATIONS

- Automotive Camera Modules
 - Surround View Camera
 - Front View Camera
 - Rear View Camera
 - Driver Monitoring System
 - Cabin Monitor
 - Dash Cam DVR
 - eMirror
- Automotive Sensor Applications
- Automotive Secondary Regulation
- Space Constrained Applications

TYPICAL APPLICATION

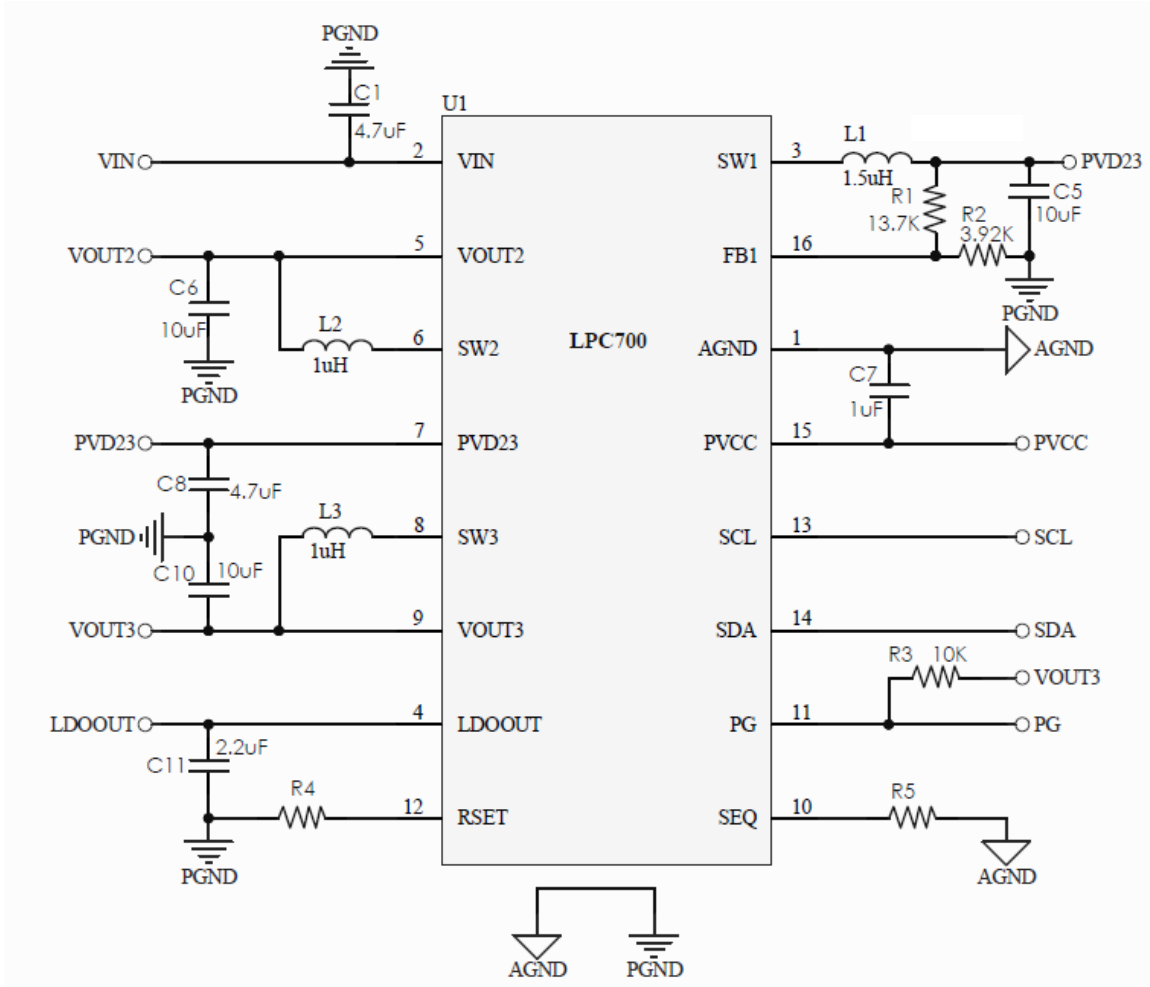
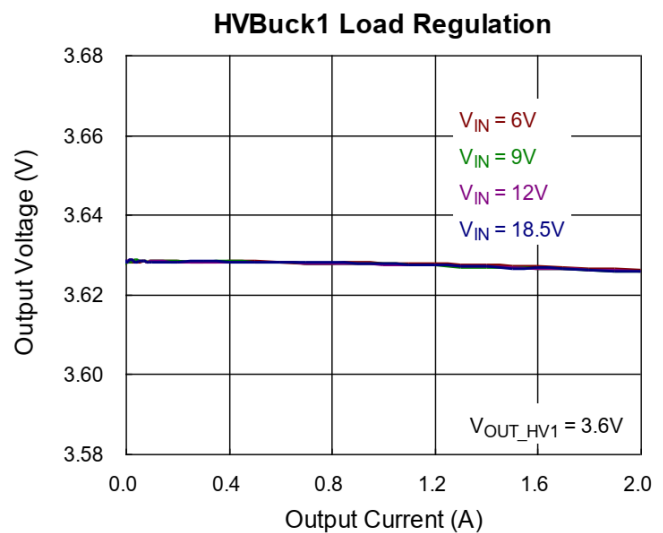
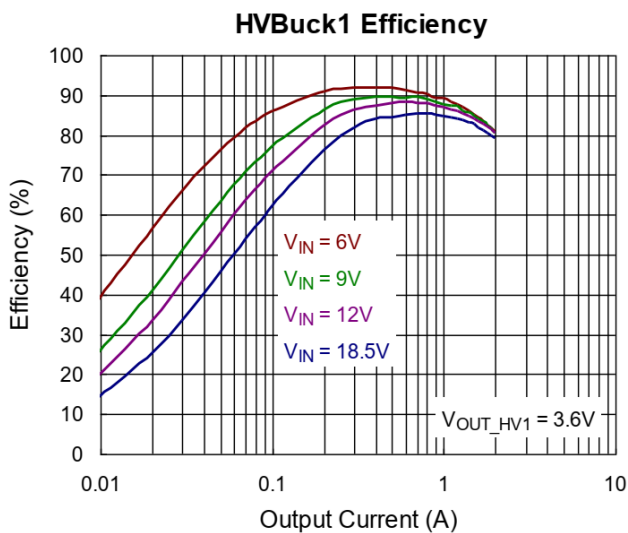
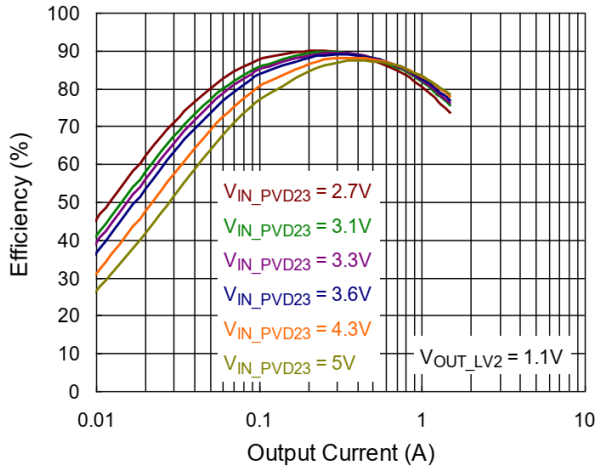

Figure 1. Typical Application



LVBuck2 Efficiency



LVBuck2 Load Regulation

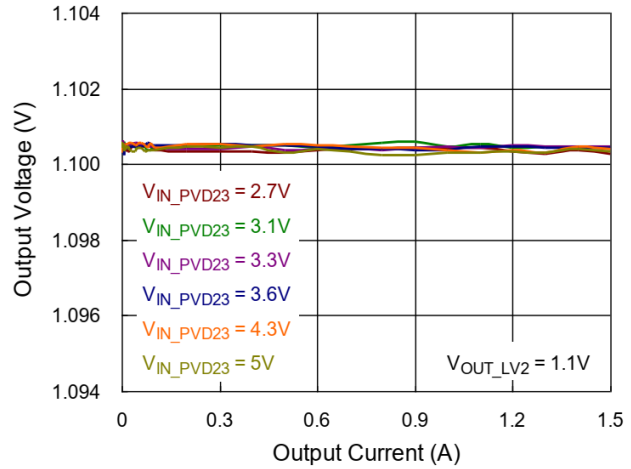

LVBuck3 Efficiency

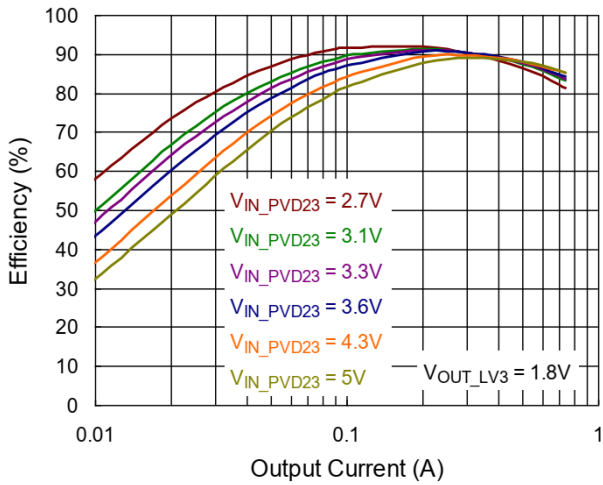

LVBuck3 Load Regulation

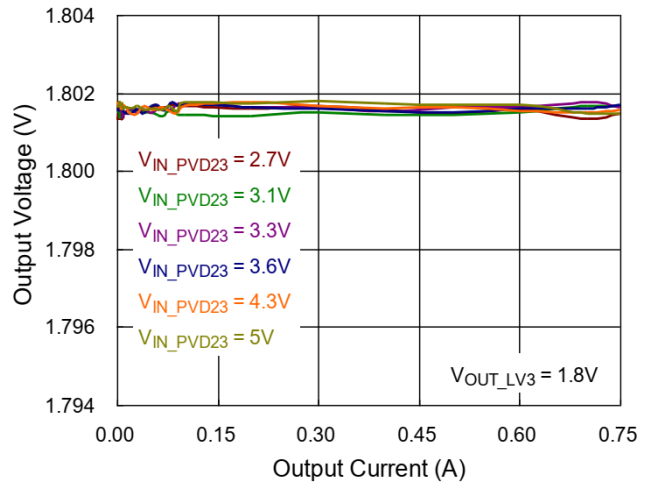

LDO Load Regulation

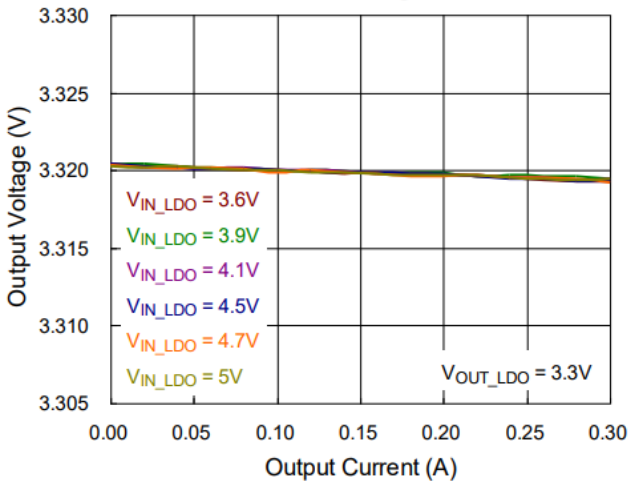

LDO Dropout Voltage vs. Output Current

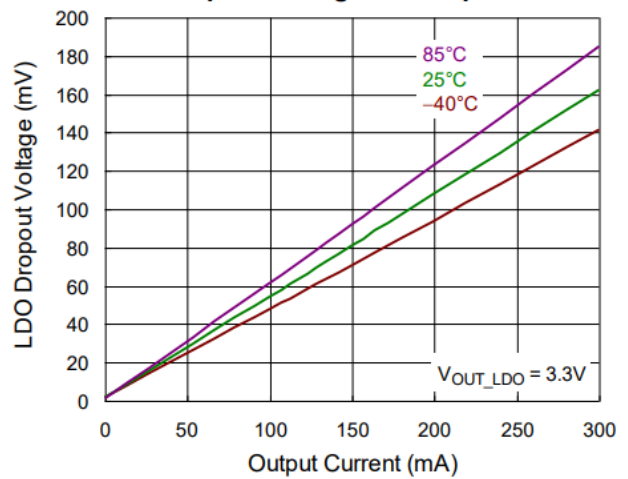

Pin Configuration

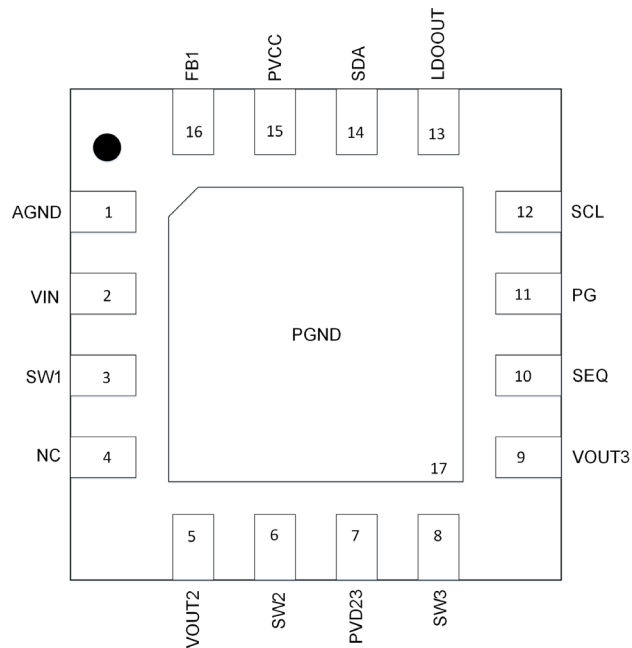

QFN-16 (3mm x 3mm)

Pin Description

Pin No.	Pin Name	Pin Function
1	AGND	Analog ground.
2	VIN	Supply voltage input of HVBuck1. Connect a 4.7uF or larger decouple ceramic capacitor between this pin and ground
3	SW1	HVBuck1 switch node.
4	NC	Connect to ground
5	VOUT2	Output voltage feedback input of LVBuck2. Directly connect the output capacitor node to this pin for better regulation.
6	SW2	LVBuck2 switch node.
7	PVD23	Supply voltage input of LVBuck2 and LVBuck3. Connect a 4.7uF or larger decouple ceramic capacitor between this pin and ground.
8	SW3	LVBuck3 switch node
9	VOUT3	Output voltage feedback input of LVBuck3. Directly connect the output capacitor node to this pin for better regulation.
10	SEQ	Power sequence selection
11	PG	Power status indication pin with open drain structure for HVBuck1, LVBuck2, LVBuck3 and LDO. PG at high state indicates all outputs work well.
12	SCL	I2C clock pin. An external pull-up resistor is needed to connect this pin to the supply rail of the I2C. Connect to ground if not used.
13	LDOOUT	LDO output. Connect a 2.2uF ceramic decouple capacitor between this pin and ground.
14	SDA	I2C data pin. An external pull-up resistor is needed to connect this pin to the supply rail of the I2C. Connect to ground if not used.
15	PVCC	Internal analog power output. Connect a 1uF ceramic decouple capacitor between this pin and ground. Note additional external loading on this pin is forbidden.
16	FB1	Output voltage feedback input of HVBuck1.

ABSOLUTE MAXIMUM RATINGS

- VIN----- -0.3V to 24V
- SW1----- -0.3V to 24V
- VOUT2, PVD23, VOUT3, SEQ, PG, LDOOUT, PVCC, FB1----- -0.3V to 6.5V
- SW2, SW3----- -0.3V to 6.5V
- Power Dissipation, PD @Ta=25°C QFN-16L 3x3 ----- 4.16W
- Package Thermal Resistance
- VQFN-16L 3x3, θ_{JA} ----- 30°C/W
- VQFN-16L 3x3, θ_{JC} ----- 4.4°C/W
- Lead Temperature (Soldering, 10 sec.)----- 260°C
- Junction Temperature-----150°C
- Storage Temperature ----- -65~150°C
- ESD Susceptibility HBM----- 2KV

Recommended

- Supply Voltage , VIN----- 4V to 18V
- Supply Voltage , VPVD23, VLDOIN----- 2.7V to 5V
- Ambient Temperature Range----- -40~125°C
- Junction Temperature Range----- -40~150°C

Electrical Characteristics

($T_A = T_J = -40^{\circ}\text{C}$ to 125°C , $V_{IN} = 6\text{V}$, $V_{OUT_HV1} = 3.6\text{V}$, $V_{OUT_LV2} = 1.1\text{V}$, $V_{OUT_LV3} = 1.8\text{V}$, $V_{OUT_LDO} = 3.3\text{V}$, unless otherwise specified)

Parameter	Symbol	Test Conditions	Min	Typ	Max	Unit
System						
Under-Voltage Lockout Threshold	UVLO_H	VIN rising	3.6	3.8	4	V
	UVLO_L	VIN falling	3.15	3.3	3.45	V
Input Over-Voltage Protection	VIN_OV		18.6	20	21.5	V
Oscillator						
Switching Frequency	Fsw	FREQUENCY[1] = 0	2	2.2	2.4	MHz
		FREQUENCY[1] = 1	3	3.3	3.6	
Minimum On Time	ton_MIN			48		ns
Minimum Off Time	toff_MIN			40		ns
CH1 HVBUCK1						
Input Voltage Range	VIN		4	--	18.5	V
Output Voltage Range	VOUT_HV1	Buck mode operation. Switching frequency, minimum on time and minimum off time need to be considered.	2.7	--	5	V
Output Feedback Voltage Accuracy	VFB1		0.788	0.8	0.812	V
High-Side MOSFET On Resistance	RON_HS_HV1	From VIN pin to SW1 pin	115	210	340	m Ω
Low-Side MOSFET On Resistance	RON_LS_HV1	From SW1 pin to PGND pin	40	110	200	m Ω
Inductor Peak Current Limit	ICL_PK_HV1		2.4	3	3.6	A
Inductor Valley Current Limit	ICL_VL_HV1		--	2.7	--	A
Negative Inductor Peak Current Limit	ICL_NPK_HV1		1	2.5	4	A
Output Discharge Resistor	RDIS_HV1		230	270	360	Ω
Output Under-Voltage Falling Threshold	UVP_F_HV1		40	50	60	%
Output Feedback Over-Voltage Rising Threshold	OVP_R_HV1		--	110	--	%

Parameter	Symbol	Test Conditions	Min	Typ	Max	Unit
CH2 LVBUCK2 (VIN_PVD23 = 3.6V)						
Input Voltage Range	VIN_PVD23		2.7	--	5	V
Output Voltage	VOUT_LV2		--	1.1	--	V
Output Voltage Accuracy	VOUT_ACC_LV2		-1	--	1	%
High-Side MOSFET On Resistance	RON_HS_LV2	From PVD23 pin to SW2 pin	110	150	215	mΩ
Low-Side MOSFET On Resistance	RON_LS_LV2	From SW2 pin to PGND pin	60	90	145	mΩ
Inductor Peak Current Limit	ICL_PK_LV2		1.8	2.2	2.6	A
Inductor Valley Current Limit	ICL_VL_LV2		--	1.8	--	A
Negative Inductor Peak Current Limit	ICL_NPK_LV2		0.7	1.7	2.9	A
Output Discharge Resistor	RDIS_LV2		6	9	4	Ω
Output Under-Voltage Falling Threshold	UVP_F_LV2		40	50	60	%
Output Feedback Over-Voltage Rising Threshold	OVP_R_LV2		--	120	--	%
Output Over-Voltage Falling Threshold	OVP_F_LV2		--	110	--	%
Input Over-Voltage Rising Threshold	OVP_IN_R_LV2		5.35	5.8	6.25	V
Input Over-Voltage Hysteresis	OVP_IN_HYS_LV2	VIN_PVD23 falling	--	580	--	mV
CH3 LVBUCK3 (VIN_PVD23 = 3.6V)						
Input Voltage Range	VIN_PVD23		2.7	--	5	V
Output Voltage	VOUT_LV3		--	1.8	--	V
Output Voltage Accuracy	VOUT_ACC_LV3		-1	--	1	%
High-Side MOSFET On Resistance	RON_HS_LV3		240	310	440	mΩ
Low-Side MOSFET On Resistance	RON_LS_LV3		170	230	360	mΩ
Inductor Peak Current Limit	ICL_PK_LV3		0.96	1.2	1.44	A
Inductor Valley Current Limit	ICL_VL_LV3		--	1.08	--	A
Negative Inductor Peak Current Limit	ICL_NPK_LV3		0.7	1.7	2.9	A
Output Discharge Resistor	RDIS_LV3		7	10	15	Ω
Output Under-Voltage Falling Threshold	UVP_F_LV3		40	50	60	%
Output Feedback Over-Voltage Rising Threshold	OVP_R_LV3		--	120	--	%
Output Over-Voltage Falling Threshold	OVP_F_LV3		--	110	--	%
Input Over-Voltage Rising Threshold	OVP_IN_R_LV3		5.35	5.8	6.25	V
Input Over-Voltage Hysteresis	OVP_IN_HYS_LV3		--	580	--	mV

Parameter	Symbol	Test Conditions	Min	Typ	Max	Unit
CH4 LDO (VIN_PVD23 = 3.6V)						
Input Voltage Range	VIN_PVD23		2.7	--	5	V
Output Voltage Range	VOUT_LDO	VOUT_LDO setting via RSET	1.8	--	3.5	V
Output Voltage Accuracy	VOUT_ACC_LDO	V IOUT_LDO IN_LDO - = 0mA to 300mA VOUT_LDO > 0.3V,	-1	--	1	%
Maximum Output Current	IOUT_MAX_LDO		300	--	--	mA
Dropout Voltage	VDROP_LDO	IOUT_LDO = 300mA (Note 5)	--	--	300	mV
Output Current Limit	ICL_LDO		345	450	555	mA
Output Discharge Resistor	RDIS_LDO		48	76	104	Ω
Output Under-Voltage Falling Threshold	UVP_F_LDO		40	50	60	%
Output Feedback Over-Voltage Rising Threshold	OVP_R_LDO		--	125	--	%
Output Over-Voltage Falling Threshold	OVP_F_LDO		--	110	--	%
Input Over-Voltage Rising Threshold	OVP_IN_R_LDO		5.35	5.8	6.25	V
Input Over-Voltage Hysteresis	OVP_IN_HYS_LDO		--	500	--	mV
PVCC						
Internal Regulator Output Voltage	VOUT_PVCC		4.33	4.58	4.83	V
Over-Current Limit	ICL_PVCC		150	--	300	mA
Power Good						
Pull Down Voltage	VOUT_L_PG	Current into PG pin equal to 5mA	--	--	200	mV
Input Leakage Current	ILEAK_PG	1.8V applied on PG pin	--	--	1	μ A
Timing						
Soft-Start Time	tSS_HV1	Time from VOUT_HV1 0% rise to 90% of target value, no load	500	1000	1500	us
	tSS_LV2	Time from VOUT_LV2 0% rise to 90% of target value, no load	500	1000	1500	
	tSS_LV3	Time from VOUT_LV3 0% rise to 90% of target value, no load	500	1000	1500	
	tSS_LDO	Time from the previous turn on channel's output voltage reaching 90% of target value to VOUT_LDO rise to 90% of target value.	200	700	1100	
PG Delay Time	tDLY_PG		9	10	11	ms

System Characteristics

The following specifications are guaranteed by design and are not performed in production testing. ($T_A = T_J = -40^{\circ}\text{C}$ to 125°C , $V_{IN} = 6\text{V}$, $V_{OUT_HV1} = 3.6\text{V}$, $V_{OUT_LV2} = 1.1\text{V}$, $V_{OUT_LV3} = 1.8\text{V}$, $V_{OUT_LDO} = 3.3\text{V}$, unless otherwise specified.)

Parameter	Symbol	Test Conditions	Min	Typ	Max	Unit
System						
Over-Temperature Protection	OTP		--	160	--	$^{\circ}\text{C}$
Over-Temperature Protection Hysteresis	OTP_H		--	20	--	$^{\circ}\text{C}$
CH1 HV BUCK1						
Maximum Output Current	IOUT_MAX_HV1		2	--	--	A
Load Regulation	VLOAD_REG_HV1	IOUT_HV1 = 0A to 2A	--	--	0.1	%/A
Line Regulation	VLINE_REG_HV1	$V_{IN} = 5\text{V}$ to 18.5V , IOUT_HV1 = 2A	--	--	1	%
Load Transient	VLOAD_TRAIN_HV1	IOUT_HV1 = 10mA to 500mA to 10mA, $1\mu\text{s}$	-150	--	150	mV
Line Transient	VLINE_TRAIN_HV1	$V_{IN} = 5\text{V}$ to 18.5V to 5V , $100\mu\text{s}$, IOUT_HV1 = 10mA/500mA	-50	--	50	mV
Output Ripple	VRIPPLE_HV1	Peak to peak in one switching cycle	--	--	20	mVpp
CH2 LV BUCK2						
Maximum Output Current	IOUT_MAX_LV2		1.5	--	--	A
Load Regulation	VLOAD_REG_LV2	IOUT_LV2 = 0A to 1.5A	--	--	0.1	%/A
Line Regulation	VLINE_REG_LV2	$V_{IN_PVD23} = 2.7\text{V}$ to 5V , IOUT_LV2 = 1.5A	--	--	1	%
Load Transient	VLOAD_TRAIN_LV2	IOUT_LV2 = 10mA to 500mA to 10mA, $1\mu\text{s}$	-50	--	50	mV
Line Transient	VLINE_TRAIN_LV2	$V_{IN_PVD23} = 3\text{V}$ to 5V to 3V , $50\mu\text{s}$, IOUT_LV2 = 10mA/1A	-50	--	50	mV
Output Ripple	VRIPPLE_LV2	Peak to peak in one switching cycle	--	--	10	mVpp
CH3 LV BUCK3						
Maximum Output Current	IOUT_MAX_LV3		0.75	--	--	A
Load Regulation	VLOAD_REG_LV3	IOUT_LV3 = 0A to 750mA	--	--	0.1	%/A
Line Regulation	VLINE_REG_LV3	$V_{IN_PVD23} = 2.7\text{V}$ to 5V , IOUT_LV3 = 750mA	--	--	1	%
Load Transient	VLOAD_TRAIN_LV3	IOUT_LV3 = 10mA to 300mA to 10mA, $1\mu\text{s}$	-50	--	50	mV
Line Transient	VLINE_TRAIN_LV3	$V_{IN_PVD23} = 3\text{V}$ to 5V to 3V , $50\mu\text{s}$, IOUT_LV3 = 10mA/300mA	-50	--	50	mV
Output Ripple	VRIPPLE_LV3	Peak to peak in one switching cycle	--	--	10	mVpp

Parameter	Symbol	Test Conditions	Min	Typ	Max	Unit
LDO						
Power Supply Rejection Ratio	PSRR_LDO	IOUT_LDO = 100mA, f = 100kHz	--	60	--	dB
		IOUT_LDO = 100mA, f = 2MHz	--	55	--	
Output Noise Voltage	EN_LDO	IOUT_LDO=100mA, f=100Hz to 100kHz	--	60	--	μV
Load Transient	VLOAD_TRAIN_LDO	IOUT_LDO = 10mA to 200mA to 10mA, 1μs	-25	--	25	mV
Line Transient	VLINE_TRAIN_LDO	All VOUT_LDO, VIN_LDO step 600mV, LDO not in dropout condition, 10μs, IOUT_LDO = 1mA/300mA	-25	--	25	mV
Component Requirement						
Input Capacitance	CIN_HV1		1.5	4.7	10	uF
	CIN_PVD23		1.5	4.7	10	
Output Capacitance	COUT_HV1		3.3	10	14	uF
	COUT_LV2		4.5	10	14	
	COUT_LV3		4.5	10	14	
	COUT_LDO		0.7	2.2	4	
Output Inductance	LHV1		1	1.5	2	uH
	LLV2		0.68	1	1.2	
	LLV3		0.68	1	1.2	
PVCC Capacitance	CPVCC		0.3	1	1.4	μF

Note 1. Stresses beyond those listed under “Absolute Maximum Ratings” may cause permanent damage to the device. These are stress ratings only, and functional operation of the device at these or any other conditions beyond those indicated in the operational sections of the specifications is not implied. Exposure to absolute maximum rating conditions may affect device reliability.

Note 2. θ_{JA} is measured under natural convection (still air) at $T_A = 25^\circ\text{C}$ with the component mounted on a high effective-thermal-conductivity four-layer test board on a JEDEC 51-7 thermal measurement standard. θ_{JC} is measured at the exposed pad of the package.

Note 3. Devices are ESD sensitive. Handling precaution is recommended.

Note 4. The device is not guaranteed to function outside its operating conditions.

Note 5. Dropout voltage is the voltage difference between the input and the output at which the output voltage drops to 100 mV below its nominal value.

Note 6. PVCC is the pre-regulator output voltage only for internal circuitry. External loading on PVCC pin is forbidden

Parameter	Symbol	Condition	Min	Typ	Max	Units
I2C interface						
I2C ready time	T_{PMB_R}	From $V_{IN} > UVLO$ to I2C Ready			12	ms
Input Logic High	V_{IH}		1.4			V
Input Logic Low	V_{IL}				0.4	V
Output Voltage Logic Low	V_{OUT_L}	RSTO pin sink 4mA			0.4	V
SCL Clock Frequency	fSCL				400	kHz
SCL High Time	tHIGH		60			ns
SCL Low Time	tLOW		160			ns
Data Setup Time	tSU.DAT		10			ns
Data Hold Time	tHD.DAT			70		ns
Setup Time for Repeated Start	tSU.STA		160			ns
Hold Time for (repeated)Start	tHD.STA		160			ns
Bus Free Time between a Start and a Stop Condition	tBUF		160			ns
Setup Time for Stop Condition	TSU.STO		160			ns
Rise Time of SCL and SDA	tR		10		300	ns
Fall Time of SCL and SDA	tF		10		300	ns
Pulse width of Suppressed Spike	tSP		0		50	ns
Capacitance Bus for Each Bus Line	CB				400	pF

Notes:

- 5) Guaranteed by design and bench characterization, not tested in production.
- 6) Power good threshold is based on nominal output voltage of each output

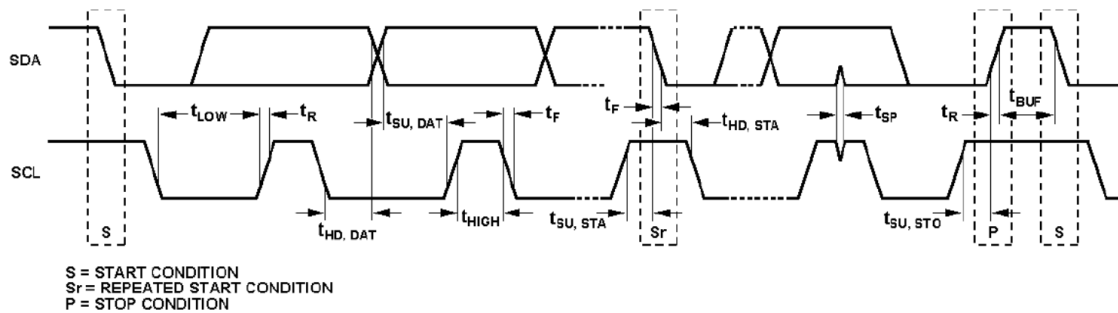

Figure2: I2C Compatible Interface Timing Diagram

FUNCTION BLOCK DIAGRAM

Figure3: Block Diagram

Operation

The LPC700 is a highly integrated power-management integrated circuit (PMIC) for automotive camera system, which includes three step-down converters (CH1 HV Buck1, CH2 LV Buck2, CH3 LV Buck3) and one generic LDO (CH4 LDO).

System Under-Voltage Protection and Over-Voltage Protection

The LPC700 stops operating if V_{IN} voltage falls below the Under-Voltage Lock Out level (UVLO_L). There is a typical 500mV hysteresis implemented to avoid unstable on/off behaviors. The shift values of UVLO_H and UVLO_L both toward to the same direction. (To positive or negative at the same time.) The device is initialized in its default state after V_{IN} voltage recovering from UVLO_H. When V_{IN} voltage reaches the Over-Voltage Protection level, the DC/DC converters, LDO are disabled immediately. Then the IC enters into latch off state and only can re-start with V_{IN} ON/OFF. Meanwhile, the PG status will be also set to 0V to indicate IC fault condition, the register indicate "1" and the faults will feedback to MCU by I2C.

Bucks1, 2, 3, and LDO. Buck2 and Buck3 output voltages are sensed at the VOUT2 and VOUT3 pins respectively, while LDO is sensed at the LDOOUT pin. Buck1 UV and OV sensing uses the PVD23 input pin; Buck1 output regulation uses the FB1 input pin. This separation on Buck1 provides protection against cases where the feedback path is interrupted because of events such as an opened solder joint.

Thermal Protection

The LPC700 features an over-temperature protection (OTP). When the junction temperature is higher than 160°C typical value, OTP is triggered to disable all outputs and the device enters into a latch off state. When the LPC700 recovers from OTP, the device only can re-start with V_{IN} ON/OFF.

Pre-Regulator

The device integrates a 4.45V linear regulator (PVCC) supplied by V_{IN} to provide power to the internal circuitry. The PVCC can be used as the RSET and SEQ pull-up supply but it is "NOT" allowed to power other device or circuitry. A 1uF decoupling capacitor must be connected between PVCC and AGND to filter the noise and it needs to be placed as close as possible to the PVCC pin.

Peak Current Mode Control

The three step-down converters utilize the peak current mode control. An internal oscillator initiates turn-on of the high-side MOSFET switch. At the beginning of each clock cycle, the internal high-side MOSFET switch turns on, allowing current to ramp up in the inductor. With comparisons of the inductor peak current signal during high-side MOSFET switch on interval and the internal compensation signal derived from the sensed feedback voltage with reference voltage, the high-side MOSFET switch is turned off and inductor current continues to flow through the low-side MOSFET switch. This cycle repeats at the next clock cycle. In this way, the regulated inductor current controls duty-cycle and output voltage of the converter.

Spread-Spectrum Operation

Due to the periodicity of the switching signal, the energy concentrates in one particular frequency and its harmonics. The energy is radiated and possible to result in a potential EMI issue. The LPC700 equips a spread-spectrum function to meet CISPR and automotive EMI compliances. The spread-spectrum function is implemented by a

pseudo random sequence, the spread range and modulation rate set by register of the switching frequency. For example, when the switching frequency typical value is 2.2MHz, the frequency range varies from 2.0MHz to 2.4MHz. Therefore, the LPC700 can guarantee that the 2.2MHz switching frequency does not drop into the 1.8MHz AM band limit.

Phase-Shifted Operation

The LPC700 supports phase shift operations among the step-down converters for further easing the simultaneous switching energy radiation quantity. The internal clock is automatically shifted to different respective sub-clocks for step-down converters. For example, when two step-down converters application, the beginning turn-on time between two high-side MOSFETs will have a 180-degree phase difference. Likewise, a 120-degree phase difference when three step-down converters.

Allowable Channel Floating

For saving PCB layout space and material cost, the unused low-voltage step-down converter (CH2/CH3) is allowable to pin (SW2/SW3) floating without any inductor and output capacitor placement. The pin PVD23 is required to connect to a fixed voltage for floating detection and it is allowable without capacitor placement. The LPC700 automatically detects pin status during power-on procedure to determine whether the channel is used or not. In addition, the related failures on unused channels do not affect the device operation.

Power Good Indication

The LPC700 features an open-drain power-good output (PG) to monitor the output voltage status. Connect a pull-up resistor from PG pin to an external voltage. Note it is forbidden to use PVCC as pulled-up voltage of PG pin. When the last channel of power-on sequence reaches 90% of its target output voltage, the PG signal is pulled up to indicate "Power Good" status after 10ms tills to device disabled or any other protection happens.

External Control Output

The LPC700 features an open-drain external control output (SEQ) for external device. Connect a pull-up resistor from SEQ pin to an external voltage. Note it is forbidden to use PVCC as pulled-up voltage of SEQ pin. Referring to Table 1 for further information about power-on sequence.

Application Information

Power Sequence Control

The LP700 supports 6 power-on sequences for the step-down converters and LDO via the dedicated resistor on SEQ pin. SEQ pin is not allowable at floating state and resistance selected out of range is not guaranteed to correct power-on sequence. In addition, there is only simultaneous power-off for all outputs. To fix the resistor selection on SEQ pin before enabling the device. Any change during the power on procedure is not guarantee to the correct power-on sequence. Below table shows the power-on sequence with its corresponding resistance.

Table 1 Power- on sequence control

SEQ NO.	Resistance on SEQ			Sequence			
	MIN	TYP	MAX				
SEQ0	1.07M	1.1M	1.13M	CH1	CH2	CH3	CH4

SEQ1	319k	330k	341k	CH1	CH2	CH4	CH3
SEQ2	164k	169k	174k	CH1	CH3	CH2	CH4
SEQ3	81.6k	84.5k	87.4k	CH1	CH3	CH4	CH2
SEQ4	45.4k	47k	48.6k	CH1	CH4	CH2	CH3
SEQ5	26.1k	27k	27.9k	CH1	CH4	CH3	CH2

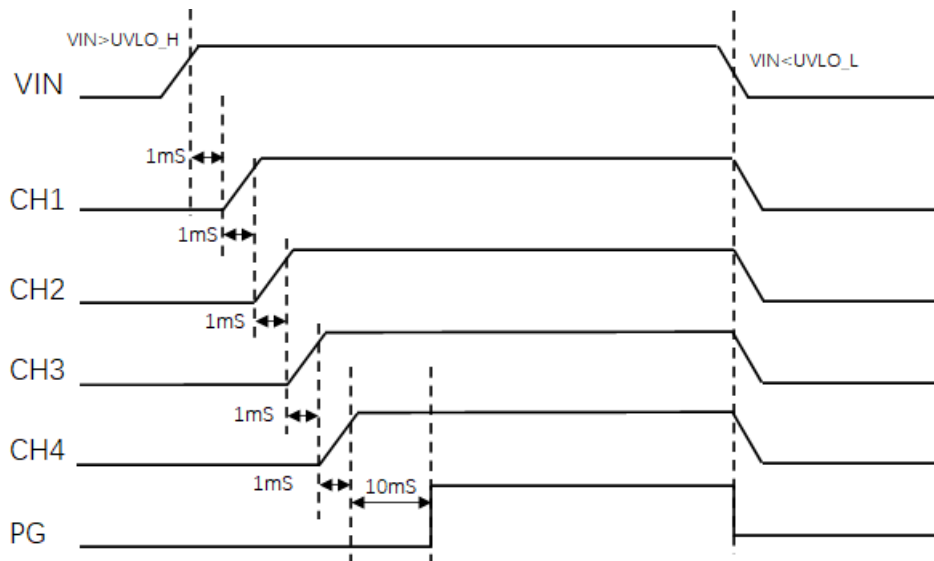

Figure 3. Example SEQ0

Output Voltage Setting

HVBuck1

The output voltage set by external feedback resistors expressed in the following equation.

$$VOUT_HV1 = (1 + R1/R2) \times VFB1$$

Where the reference voltage VFB1 is 0.8V (typ.) The placement of the resistive divider should be as close as possible to the FB1 pin. For better output voltage accuracy, the divider resistors with ±1% tolerance or better should be used. The resistance ranges from few kΩ to hundreds of kΩ is recommended.

LVBuck2 and LVBuck3

The output voltage of LVBuck2 is fixed 1.1V as default.
The output voltage of LVBuck3 is fixed 1.8V as default.

LDO

The LDO output voltage is controlled by setting the dedicated resistor on RSET pin. RSET pin is not allowable at floating state and resistance selected out of range is not guaranteed to correct output voltage. Changing of the output voltage real time is not recommended. To fix the resistor selection on RSET pin before enabling the device.

Table 2 LDO Output Voltage

RSET No	Resistor on REST (Ω)			V
	Min	Typ	Max	
RSET0	1.07M	1.1M	1.13M	3.5
RSET1	319k	330k	341k	3.4
RSET2	164k	169k	174k	3.2
RSET3	81.6k	84.5k	87.4k	3.1
RSET4	45.4k	47k	48.6k	3.0
RSET5	26.1k	27k	27.9k	2.8
RSET6	14.5k	15k	15.5k	2.7
RSET7	7.78k	8.06k	8.34k	1.8
RSET8	Short to PVCC			2.9
RSET9	Short to PGND			3.3

Channel Protection Features

The LP700 equips protections to prevent the device from damages causing by abnormal operations or fault conditions. (Over-load, Short-circuit, Soldering issue...etc.)

- **Under-Voltage Protection for output voltage (UVP)**

- **HVBuck1, LVBuck2, LVBuck3 and LDO**

The device disables all channels and enters into latch off state if step-down converter or LDO output under voltage fault detected continuously over deglitch time and the device only can re-start with $V_{IN} > 3.8V$, and the Register SAFETY_01 will flag "1".

- **Over-Voltage Protection (OVP)**

- **HVBuck1**

When FB1 pin over-voltage fault detected, the high-side and low-side MOSFETs turn off immediately and the Register SAFETY_01 [Bit 3] will flag "1", PG flag will assert, auto-recover to switch until FB1 pin's voltage decrease to the reset level, and need to sent the Clear_Faults command to clear Register SAFETY_01 [Bit 3], PG flag will de-assert.

- **LVBuck2, LVBuck3 and LDO**

The device disables all channels when step-down converter or LDO output over-voltage fault detected continuously over deglitch time, and the Register SAFETY_01 [Bit 2:0] will flag "1". When the fault released, the device auto-restarts all channels in sequence. Need to sent the Clear_Faults command to clear the Register SAFETY_01 [Bit 2:0].

- **Over-Current Protection (OCP)**

- **HVBuck1, LVBuck2 and LVBuck3**

The step-down converter includes a cycle-by-cycle high-side MOSFET peak current-limit protection against the condition that the inductor current increasing abnormally, even over the inductor saturation current rating. If an over-current condition occurs, the controller will immediately turn off the high-side MOSFET and turn on the low-side MOSFET to prevent the inductor current exceeding the peak current limit level. After inductor current decreasing to below the valley current limit, the high-side MOSFET resume switching on. If over-current fault further detected continuously over than deglitch time, the device disables all channels and enters into latch off state and the device only can re-start with V_{IN} ON/ OFF. and the Register SAFETY_02 [Bit 3:1] will flag "1". When the fault released, the device auto-restarts all channels in sequence. Need to sent the Clear_Faults command to clear the Register SAFETY_02 [Bit 3:1].

■ LDO

When the load reaches the current limit threshold, the current sent to the output will kept at current limit level. If over-current fault detected continuously over than the deglitch time, the device disables all channels and enters into latch off state and the device only can re-start with VIN ON/ OFF, and the Register SAFETY_02 [Bit 0] will flag "1". When the fault released, the device auto-restarts all channels in sequence. Need to sent the Clear_Faults command to clear the register SAFETY_02 [Bit 0].

● Input Over-Voltage Protection (OVP)
■ LVBuck2, LVBuck3 and LDO

If the input voltage of step-down converters (LVBuck2, LVBuck3) or LDO reaches over-voltage protection level, the device disables all channels. After fault removed, it auto-restarts all channels in sequence.

Table3. Protection List

Channel	Type	Threshold (Typ.)	Deglitch Time (Typ.)	Channels Behavior	Reset and Threshold (Typ.)
Base	BIST	NA	NA	All channel stay disable	
System	UVLO	$V_{IN} \leq 3.3V$ (after IC Operation)	32 μ s	Disable all channels	$V_{IN} \geq 3.8V$
	OVP	$V_{IN} \geq 20V$	5ms	Disable all channels then latch-off protection	$V_{IN} \leq 3.3V$, then $V_{IN} \geq 3.8V$
	OTP	$T_J \geq 160^\circ C$	5 μ s	Disable all channels then latch-off protection	$T_J \leq 140^\circ C$ and $V_{IN} \leq 3.3V$, then $V_{IN} \geq 3.8V$
CH1 HVBuck1	UVP	$V_{FB1} \leq 0.8V \times 50\%$	5 μ s	Disable all channels then latch-off protection	$V_{IN} \leq 3.3V$, then $V_{IN} \geq 3.8V$
	OVP	$V_{FB1} \geq 0.8V \times 110\%$	NA	High MOSFETs off, low-side MOSFET conditionally ON .	$V_{FB1} < 0.8V \times 110\%$
	OCP	$IL1_{peak} \geq 3A$	10ms	Cycle-by-cycle detection If keep 10ms, disable all channels then latch-off protection.	If latch-off protection, $V_{IN} \leq 3.3V$, then $V_{IN} \geq 3.8V$
CH2 LVBuck2	UVP	$V_{OUT_LV2} \leq 1.1V \times 50\%$	5 μ s	Disable all channels then latch-off protection	$V_{IN} \leq 3.3V$ then $V_{IN} \geq 3.8V$
	OVP	$V_{OUT_LV2} \geq 1.1V \times 120\%$	5ms	Disable all channels	$V_{OUT2} \leq 1.1V \times 110\%$ with deglitch 5ms
	OCP	$IL2_{peak} \geq 2A$	10ms	Cycle-by-cycle detection If keep 10ms, disable all channels then latch-off protection.	If latch-off protection, $V_{IN} \leq 3.3V$, then $V_{IN} \geq 3.8V$
	Input OVP	$V_{IN_PVD23} \geq 5.8V$	5 μ s	Disable all channels	$V_{IN_PVD23} \leq 5.22V$ with deglitch 5us
CH3 LVBuck3	UVP	$V_{OUT_LV3} \leq 1.8V \times 50\%$	5 μ s	Disable all channels then latch-off protection	$V_{IN} \leq 3.3V$ then $V_{IN} \geq 3.8V$
	OVP	$V_{OUT_LV3} \geq 1.8V \times 120\%$	5ms	Disable all channels	$V_{OUT3} \leq 1.8V \times 110\%$ with Deglitch 5ms
	OCP	$IL3_{peak} \geq 2A$	10ms	Cycle-by-cycle detection If keep 10ms, disable all channels then latch-off protection.	If latch-off protection, $V_{IN} \leq 3.3V$, then $V_{IN} \geq 3.8V$
	Input OVP	$V_{IN_PVD23} \geq 5.8V$	5 μ s	Disable all channels	$V_{IN_PVD23} \leq 5.22V$ with deglitch 5us
CH4 LDO	UVP	$V_{OUT_LDO} \geq V_{OUT_LDO} \text{ setting} \times 40\%$	5 μ s	Disable all channels then latch-off protection	$V_{IN} \leq 3.3V$ then $V_{IN} \geq 3.8V$

	OVP	VOUT_LDO ≥ VOUT_LDO x 125%	5ms	Disable all channels	VOUT_LDO ≤ VOUT_LDO x 110% with deglitch 5ms
	OCP	IOUT_LDO ≥ 450mA	10ms	Disable all channels then latch-off protection	VIN ≤ 3.3V, then VIN ≥ 3.8V
	Input OVP	VIN_LDO ≥ 5.8V	5μs	Disable all channels	V with deglitch 5 IN_LDO ≤ 5.3Vμs

Input and Output Capacitor Selection

● HVBuck1, LVBuck2 and LVBuck3

It is recommended at least a 4.7μF input capacitor with a 10μF output capacitor for step-down converters. The ripple voltage is an important index for choosing output capacitor. This portion consists of two parts. One is the product of ripple current with the ESR of the output capacitor, while the other part is formed by the charging and discharging process of the output capacitor. The output ripple can be calculated as below.

$$\Delta V_{OUTRipple} = \Delta V_{ESR} + \Delta V_{OUT} = \Delta V_{ESR} + \frac{\Delta I_L}{8 \times C_{out} \times f_{sw}}$$

where $\Delta V_{ESR} = I_{Crms} \times R_{cesr}$

● LDO

Like any low dropout regulator, the external capacitor of the LPC700 must be carefully selected for regulator stability and performance. Using a 2.2μF capacitor for the LDO's input and output is suitable. Additional capacitor paralleled on the output may get better noise suppression but also lead to higher input inrush current when LDO outputs. It should be taken into consideration carefully.

Thermal Considerations

The junction temperature should never exceed the absolute maximum junction temperature $T_{J(MAX)}$, listed under Absolute Maximum Ratings, to avoid permanent damage to the device. The maximum allowable power dissipation depends on the thermal resistance of the IC package, the PCB layout, the rate of surrounding airflow, and the difference between the junction and ambient temperatures. The maximum power dissipation can be calculated using the following formula :

$$P_{D(max)} = (T_{J(MAX)} - T_A) / \theta_{JA}$$

where $T_{J(MAX)}$ is the maximum junction temperature;

T_A is the ambient temperature; and θ_{JA} is the junction-to-ambient thermal resistance. For continuous operation, the maximum operating junction temperature indicated under Recommended Operating Conditions is 150°C. The junction-to ambient thermal resistance, θ_{JA} , is highly package dependent. For a QFN-16L 3x3 package, the thermal resistance, θ_{JA} , is 30°C/W on a standard JEDEC 51-7 high effective-thermal-conductivity four layer test

board. The maximum power dissipation at $T_A = 25^\circ\text{C}$ can be calculated as below:

$$P_{D(MAX)} = \frac{(150^\circ\text{C} - 25^\circ\text{C})}{(30^\circ\text{C}/\text{W})} = 4.16\text{W}$$

for a QFN-16L 3x3 package.

The maximum power dissipation depends on the operating ambient temperature for the fixed $T_{J(MAX)}$ and the thermal resistance, θ_{JA} . The derating curves in Figure 3 allows the designer to see the effect of rising ambient temperature on the maximum power dissipation.

Layout Considerations

The PCB layout is an important step to maintain the high performance of the LPC700. Both the high current and the fast switching nodes demand full attention to the PCB layout to keep the robustness of the LPC700 through the PCB

layout. Improper layout might lead to the symptoms of poor line or load regulation, ground and output voltage shifts, stability issues, unsatisfying EMI behavior or worsened efficiency. For the best performance of the LPC700, the following PCB layout guidelines must be strictly followed.

- The trace from switching node to inductor should be as short as possible to minimized the switching loop for better EMI.
- Place the input and output capacitors close to the input and output pins respectively for good filtering.
- Keep the main power traces as wide and short as possible.
- Connect the AGND and PGND to a strong ground plane for maximum thermal dissipation and noise protection.
- Directly connect the step-down converter's output capacitor to the feedback network to avoid bouncing caused by parasitic resistance and inductance from the PCB trace.

POWER CONTROL

No Supply:

The PMIC's input pin has UVLO_L detection circuit, if the input voltage VIN is lower than the UVLO_L rising threshold, the PMIC's all functions are disabled.

Power On

The bucks and LDO are on. The PG pin switches high while the outputs are within the defined thresholds

Power Off:

All power rails are power off. When VIN is lower than its rising UVLO_L, the system will enter power off state first.

High Efficiency Buck Regulator

Buck1 to Buck3 are synchronous step-down DC/DCs which have built-in UVLO, soft-start, compensation and hiccup current limit protection. The switching clock is CCM operation.

Power Supply and UVLO

Vin is the power supply of Buck1 the bias and internal logic blocks. FB1 is the feedback of Buck1, and the power supply for Buck 2, Buck3 and LDOOUT.

Internal Soft-Start

The soft start function is implemented to prevent the PMIC output voltage from overshooting during start-up. When the PMIC starts up, the internal circuitry of each power rail generates a soft-start voltage that ramps up from 0V. The soft-start period lasts until the voltage on the soft-start capacitor exceeds the reference voltage. At this point, the reference voltage takes over.

Diagnostics

The LPC700 integrates several diagnostic features in order to improve system safety. If enabled, several built in self-test functions will run in the power off state before power on begins. Analog built in self-test (ABIST) ensures proper operation of the over voltage and under voltage comparators. If any diagnostic functions detect a failure, the power good flag will assert and the corresponding fault bit will indicate '1'. Once the fault has been cleared, the power good flag will de-assert.

The first reference (REF1) is the reference for output regulation, provided internal compensation. The second reference (REF2) is used by the OV and UV comparators, when the error of the internal compensation network or REF1 is greater than REF2, the comparators will turn off the switch, and fault

bit will indicate '1', the power good flag will assert. If the reference comes back into compliance and the fault register is cleared, the power good flag will de-assert.

Power Good

The power good pin is an open drain output. It will indicate logic high if the device is powered on, all outputs are within the power good range, and all fault registers are cleared. The Power Good is an active low output that provides a reset (low) signal to the system MCU when a fault occurs. Any faults detected can be read from the Fault Status Registers: Safety_01(), Safety_02(), Safety_03(), STAUS_MFR_SPECIFIC (), the high output level set by external resistor.

I2C Interface

I2C Serial Interface Description

The Power Management Bus (I2C) is an open-standard, power-management protocol that defines a means of communication with power conversion and other devices. I2C is a 2-wire, bidirectional serial interface, consisting of a serial data line (SDA) and a serial clock line (SCL). The lines are externally pulled to a bus voltage when they are "idle".

Connecting to the line, a master device generates the SCL signal and device address, and arranges the communication sequence.

The LPC700 works as a slave-only device which supports both the standard mode (100kbit/s) and fast mode (400kbit/s) bidirectional data transfer, adding flexibility to the power supply solution. The output voltage, transition slew rate or other interesting parameters of the converter can be instantaneously controlled by I2C interface.

Data Validity

One clock pulse is generated for each data bit transferred. The data on the SDA line must be stable during the high period of the clock. The HIGH or LOW state of the SDA line can only change when the clock signal on the SCL line is LOW (see Figure 4).

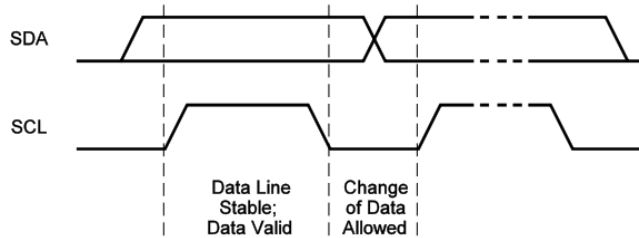

Figure4: Bit Transfer on the I2C

START and STOP Conditions

The START and STOP conditions are signaled by the master device, which signifies the beginning and the end of the I2C transfer.

The START condition is defined as the SDA signal transitioning from HIGH to LOW while the SCL line is HIGH. The STOP condition is defined as the SDA signal transitioning from LOW to HIGH while the SCL is HIGH as shown in Figure 5.

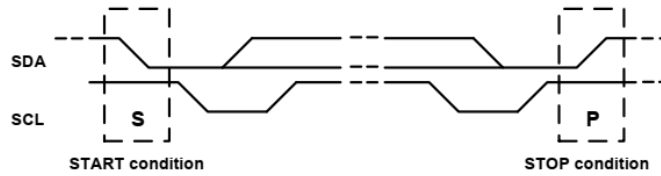

Figure 5: START & STOP Conditions

START and STOP conditions are generated always by the master. The bus is considered busy after the START condition. The bus is considered free again after a certain time after the STOP condition. The bus stays busy if a repeated START is generated instead of a STOP condition. The START and repeated START conditions are functionally identical.

Transfer Data

Every byte puts on the SDA line must be 8-bit long. Each byte must be followed by an Acknowledge bit. The acknowledge-related clock pulse is generated by the master. The transmitter releases the SDA line (HIGH) during the acknowledge clock pulse. The receiver must pull down the SDA line during the acknowledge clock pulse, so that it remains stable LOW during the HIGH period of the clock pulse. Data transfers follow the format shown in Figure 6. After the START condition, a slave address is sent. This address is 7-bits long followed by an eighth bit, which is a data direction bit (R/W). A bit “0” indicates a transmission (WRITE), and a bit “1” indicates a request for data (READ). A data transfer is terminated always by a STOP condition generated by the master. However, if a master still wishes to communicate on the bus, it can generate a repeated START condition and address another slave without first generating a STOP condition.

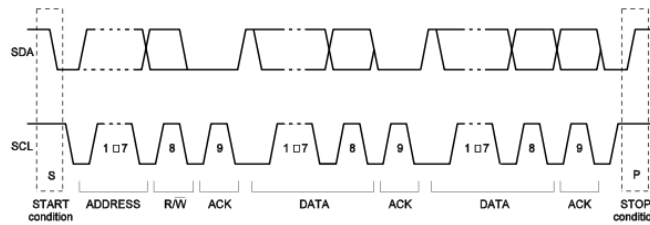

Figure 6: A Complete Data Transfer

I2C Communication Failure

A data transmission fault occurs when the data is not properly transferred between the devices. There are several data transmission faults. All sorts of faults are listed below.

- Sending too few data
- Reading too few data
- The host sends too many bytes
- The host reads too many bytes
- Improperly set read bit in the address byte
- Unsupported command code

The communication failure will be recorded in the register **STAUS_MFR_SPECIFIC**

Write/Read Sequence

All I2C commands are supported by LPC700 following the write/read sequence shown in Figure 7 and Figure 8. Five kinds of commands are implemented with or without PEC:

- 1) Send command only
- 2) Write byte

- 3) Write word
- 4) Read byte
- 5) Read word

If the master write command to a read-only register, the LPC700 performs the same action as the host sends too many bytes. If the master read command from a write-only register,

the LPC700 performs the same action as the host reads too many bytes.

Chip Address

Set ADDRESS register. The default 7bit address is 03h.

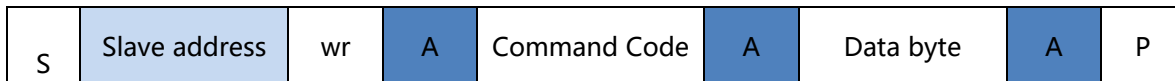

Figure 7: I2C write/read sequence

REGISTER MAP

Table4. Register Map

ADDRESS	CMD NAME	R/W	BYTES	DEFAULT
	Safety_01	R/W	1	0x00h
	Safety_02	R/W	1	0x00h
	Safety_03	R/W	1	0x00h
	Clear_Faults	W	1	0x00h
	Write_Protect	R/W	1	0x00h
	FREQUENCY_DITHER & LIGHT_LOAD	R/W	1	0x12h
	Buck2/3_ Vol_adjustable	R/W	1	0x89h
	ADDRESS	R/W	1	0x00h

DETAILED REGISTER DESCRIPTION

CLEAR_FAULTS (xxh)

This command is used to clear any fault bit in all status registers: Safety_01(), Safety_02(), Safety_03(), STAU5_MFR_SPECIFIC (). This command is write only. There is no data byte for this command.

WRITE_PROTECT (xxh)

The WRITE_PROTECT command is used to control writing to the converter. The intent of this command is to provide protection against accident changes. It's not intended to provide protection against deliberate or malicious changes to the converter's configuration or operation. All the supported commands may have their parameters read, regardless of the WRITE_PROTECT settings

Command	Write_Protect				Default:0x00			
Bit	7	6	5	4	3	2	1	0
Access	R/W	R/W	R/W	R/W	R/W	R/W	R/W	R/W

Bits	Bit Name	Description
7:0	Write_Protect	10000000: Disable all writes except to the WRITE_PROTECT command 00000000: Enable writes to all commands.

Safety_01(xxh)

The Safety_01 command returns the value of a number of flags indicating the state of the LPC700

Command	Safety_01				Default:0x00			
Bit	7	6	5	4	3	2	1	0
Access	R/W	R/W	R/W	R/W	R/W	R/W	R/W	R/W

Bits	Bit Name	Description
7	BUCK1_UVP	0:Output No Under Voltage occurred 1:Output Under Voltage occurred
6	BUCK2_UVP	0:Output No Under Voltage occurred 1:Output Under Voltage occurred
5	BUCK3_UVP	0:Output No Under Voltage occurred 1:Output Under Voltage occurred
4	LDO_UVP	0:Output No Under Voltage occurred 1:Output Under Voltage occurred
3	BUCK1_OVP	0: Output No Over Voltage occurred 1: Output Over Voltage occurred
2	BUCK2_OVP	0: Output No Over Voltage occurred 1: Output Over Voltage occurred
1	BUCK3_OVP	0: Output No Over Voltage occurred 1: Output Over Voltage occurred
0	LDO_OVP	0: Output No Over Voltage occurred 1: Output Over Voltage occurred

Safety_02(xxh)

The Safety_02 command returns the value of a number of flags indicating the state of the LPC700

Command	Safety_02				Default:0x00			
Bit	7	6	5	4	3	2	1	0
Access	R/W	R/W	R/W	R/W	R/W	R/W	R/W	R/W

Bits	Bit Name	Description
7	BUCK1_OVP	0: Input No Over Voltage occurred 1: Input Over Voltage occurred

6	BUCK2_OVP	0: Input No Over Voltage occurred	1: Input Over Voltage occurred
5	BUCK3_OVP	0: Input No Over Voltage occurred	1: Input Over Voltage occurred
4	LDO_OVP	0: Input No Over Voltage occurred	1: Input Over Voltage occurred
3	BUCK1_OCP	0: Output No Over Current occurred	1: Output Over Current occurred
2	BUCK2_OCP	0: Output No Over Current occurred	1: Output Over Current occurred
1	BUCK3_OCP	0: Output No Over Current occurred	1: Output Over Current occurred
0	LDO_OCP	0: Output No Over Current occurred	1: Output Over Current occurred

Safety_03(xxh)

The Safety_03 command returns the value of a number of flags indicating the state of the LPC700

Command	Safety_03				Default:0x00			
Bit	7	6	5	4	3	2	1	0
Access	R/W	R/W	R/W	R/W	R/W	R/W	R/W	R/W

Bits	Bit Name	Description
7	System_UVP	0: System (Vin) No Under Voltage occurred 1: System (Vin) No Under Over Voltage occurred
6	OTP	0: No Over Temperature occurred 1: Over Temperature occurred
5	ABIST_FAULT	0: No ABIST fault has occurred 1: An ABIST fault has occurred
4	CML	0: No communications, memory or logic fault has occurred. 1: A communications, memory or logic fault has occurred
3:0	Reserved	Reserved

FREQUENCY_DITHER (xxh)

Command	FREQUENCY_DITHER				Default:0x12			
Bit	7	6	5	4	3	2	1	0
Access	R/W	R/W	R/W	R/W	R/W	R/W	R/W	R/W

Bits	Bit Name	Description
7	FSS_EN	Frequency spread spectrum Control. 0: Disable (default) 1: Enable
6:5	RESERVED	RESERVED
4	SSM_RAN	0: +/-5% Spread Spectrum Modulation Range 1: +/-10% Spread Spectrum Modulation Range (default)
3	FREQUENCY	Frequency 0: 2.2MHz (Default) 1: 3.3MHz

2	RESERVED	RESERVED
1	SSM_FRE	00: 4.5kHz Spread Spectrum Modulation Frequency 01: 9kHz Spread Spectrum Modulation Frequency (default) 10: 15KHz Spread Spectrum Modulation Frequency 11: 22KHz Spread Spectrum Modulation Frequency
0	LIGHT_MODE	0: CCM (Default) 1: DCM

Buck2/3_Vol_adjustable (xxh)

Command	Buck2_adjustable, default:(1000)				Buck3_Vol_adjustable, default:(1001)			
Bit	7	6	5	4	3	2	1	0
Access	R/W	R/W	R/W	R/W	R/W	R/W	R/W	R/W

Bits	Bit Name	Description					
7:4	Vout2 output voltage setting	Buck2 output voltage setting					
		Data	Vol	Data	Vol	Data	Vol
		0000	0.7	0111	1.05	1110	1.4
		0001	0.75	1000	1.1	1111	1.45
		0010	0.8	1001	1.15		
		0011	0.85	1010	1.2		
		0100	0.9	1011	1.25		
		0101	0.95	1100	1.3		
		0110	1.0	1101	1.35		
3:0	Vout3 output voltage setting	Buck3 output voltage setting					
		Data	Vol	Data	Vol	Data	Vol
		0000	0.9	0111	1.6	1110	2.3
		0001	1.0	1000	1.7	1111	2.4
		0010	1.1	1001	1.8		
		0011	1.2	1010	1.9		
		0100	1.3	1011	2.0		
		0101	1.4	1100	2.1		
0110	1.5	1101	2.2				

ADDRESS (xxh)

Command	ADDRESS				Default:0x00			
Bit	7	6	5	4	3	2	1	0
Access	R/W	R/W	R/W	R/W	R/W	R/W	R/W	R/W

Bits	Bit Name	Description
7:4	RESERVED	RESERVED
3:0	ADDRESS	I2C ADDRESS

PACKAGE INFORMATION

COMMON DIMENSIONS
(UNITS OF MEASURE=MILLIMETER)

SYMBOL	MIN	NOM	MAX
A	0.50	0.55	0.60
A1	0.00	0.02	0.05
A3	0.15REF		
b	0.17	0.22	0.27
D	2.90	3.00	3.10
E	2.90	3.00	3.10
D2	1.70	1.80	1.90
E2	1.70	1.80	1.90
e	0.40	0.50	0.60
H	0.20REF		
K	0.20	0.30	0.40
L	0.25	0.30	0.35
R	0.085	-	-

Revision History

Revision Number	Date of Release	Changes
1.0		1: Preliminary